

# Bathroom Remodeling

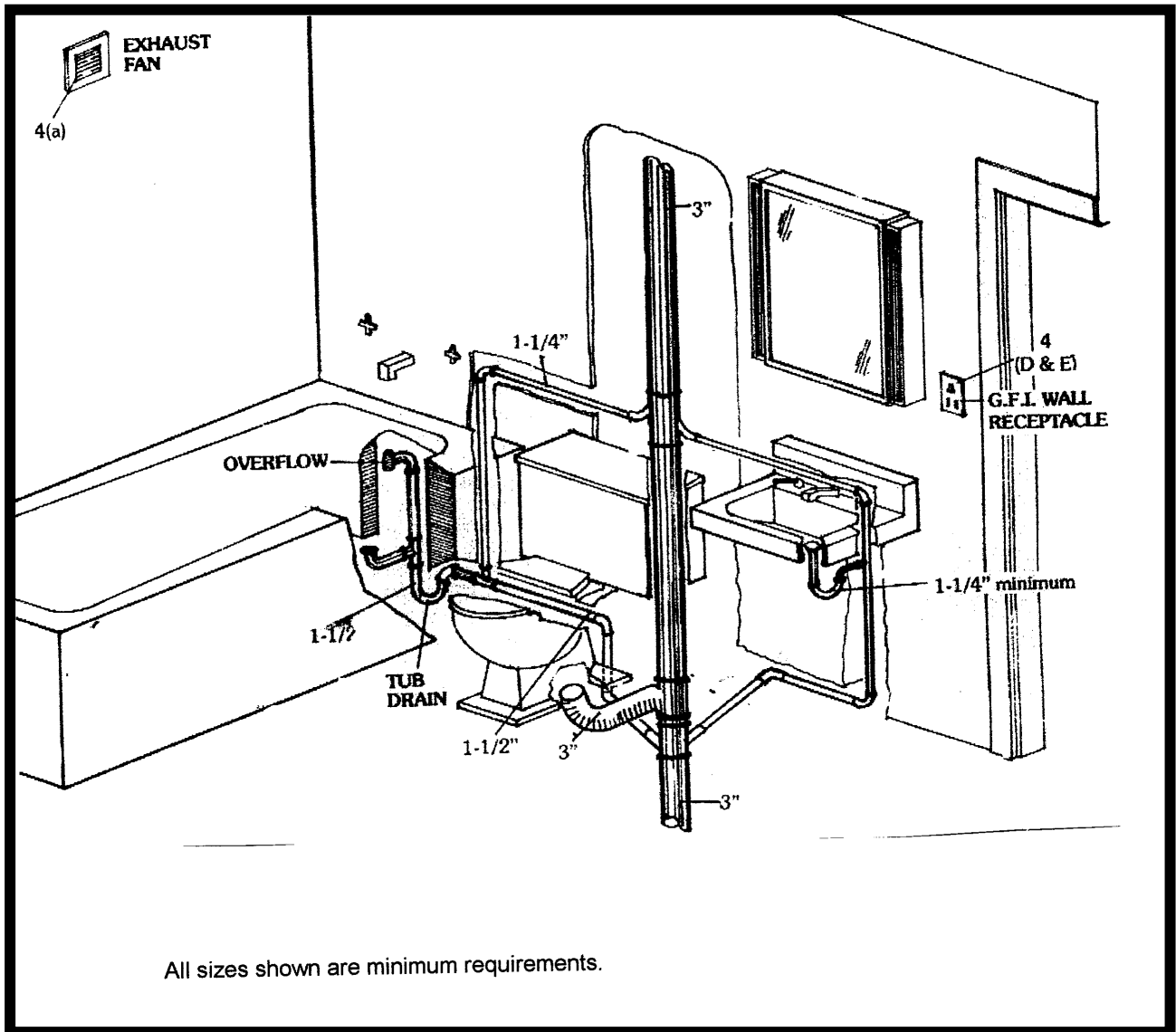

## **Requirements for Bathroom Remodeling**

1. Before remodeling a bathroom, permits must first be obtained from the Building Department.

2. Permits to be obtained are:

Building – For carpentry, vanities, soffits, flooring/sheathing, removal or installation of windows.

Electrical – For new receptacles, lighting fixtures and any electrical appliances.

Plumbing – For any replacement of plumbing fixtures (tubs, lavs and toilets).

3. When an existing bathroom is remodeled, the entire room is to be brought to current code standards. Remodeling is defined as replacing 2 or more plumbing fixtures.

4. Electrical:

- a) If the existing bathroom does not have an operable window for ventilation, an electrical, mechanical exhaust fan shall be installed and vented to outside air.
- b) At least one wall switch-controlled lighting outlet shall be installed in the bathroom.
- c) At least one wall receptacle shall be installed in the bathroom adjacent to the basin location.
- d) The above mentioned receptacle shall have ground-fault circuit interrupter protection, and be a dedicated circuit.
- e) Before concealing wiring, call the Building Department for an inspection.

5. Plumbing:

- a) Plumbing material may consist of plastic (ABS or PCV Schedule 40) or other approved materials for drain waste and vent piping.
- b) Correct waste sizes and vent sizes vary from job to job depending upon location of fixtures and location of bathroom in regard to what floor level the new plumbing is being installed.
- c) See illustration for typical first or second floor bathroom with no plumbing fixtures installed above.
- d) It is required that water supply lines to the toilet and lavatory be equipped with shut-off valves readily accessible.
- e) Before concealing plumbing, call the Building Department for an inspection.